

# CONTROL PNEUMATIC ARTIFICIAL MUSCLE MANIPULATOR WITH NONLINEAR PID CONTROLLER USING NEURAL NETWORK

Tu Diep Cong Thanh \* and Kyoung Kwan Ahn \*\*

\* Mechatronics Department, HCMC University of Technology, Viet Nam

\*\* School of Mechanical and Automotive Engineering, University of Ulsan, Korea

## ABSTRACT

A novel actuator system which has achieved increased popularity to provide these advantages such as high strength and power/weight ratio, low cost, compactness, ease of maintenance, cleanliness, readily available, cheap power source, inherent safety and mobility assistance to humans performing tasks has been the utilization of the pneumatic artificial muscle (PAM) manipulator, in recent times. However, the complex nonlinear dynamics of the PAM manipulator makes it a challenging and appealing system for modeling and control design. The problems with the time variance, compliance, high hysteresis and nonlinearity of pneumatic systems have made it difficult to realize precise position control with high speed. In order to realize satisfactory control performance, the effect of nonlinear factors contained in the PAM manipulator must be considered. The purpose of this study is to improve the control performance of the PAM manipulator using a nonlinear PID controller. Superb mixture of conventional PID controller and the neural network, which has powerful capability of learning, adaptation and tackling nonlinearity, brings us a novel nonlinear PID controller using neural network. This proposed controller is appropriate for a kind of plants with nonlinearity uncertainties and disturbances. The experiments were carried out in practical PAM manipulator and the effectiveness of the proposed control algorithm was demonstrated through the experiments.

## 1. INTRODUCTION

The PAM manipulator has been regarded during the recent decades as an interesting alternative to hydraulic and electric actuators. Its main advantages are high power/weight ratio, low cost, compactness, ease of maintenance, cleanliness, readily available and cheap power source, inherent safety and mobility assistance to humans performing tasks. However, the problems with the time variance, compliance, hysteresis and nonlinearity of pneumatic systems have made it difficult to realize precise position control with high speed. For widespread use of these actuators in the field of manipulators, it is necessary to realize precise position control without regard to the nonlinearity of the PAM manipulator.

In order to realize satisfactory control performance, many control strategies have been proposed to handle the effect of nonlinear factor contained in the PAM manipulator. The complex nonlinear dynamics of the PAM manipulator made it a challenging and appealing

system for modeling and control design. Among previous approaches, Repperger and his team had handled the nonlinear factor with a nonlinear feedback controller using a gain scheduling method [1]. Having tested a feed forward – PID regulator, Caldwell and his team were turning to develop an adaptive controller for the PAM manipulator [2]. Recently, the authors had announced that the position regulation performance of the joints of their arm prototype was better than  $\pm 0.5[^\circ]$  [3]. Cai and Yamura proposed to employ a sliding-mode control approach and was also developed by Tondu and Lopex, Carbonell and his team [4]. Other possible approaches were  $H_\infty$  control and variable structure control [5]. The fine control performance could be obtained by using some control strategies of a sliding-mode control, an adaptive control and so on. However, these systems were based on the assumption that the process to be controlled should be linear.

Furthermore, the intelligent control techniques have emerged to overcome some

deficiencies in conventional control methods in dealing with complex real-world systems in more recent years. These problems include knowledge adaptation, learning and expert knowledge incorporation. Balasubramanian and Rattan had proposed feed-forward control of a nonlinear PAM system using fuzzy logic [6]. A fuzzy inverse dynamics controller for a pneumatic system was designed and tested for the trajectory tracking capability. Fuzzy controllers have been successfully implemented for many linear and nonlinear processes.

However, there were obviously steady-state error, and also it was very difficult to implement in practice because of the difficulty in constructing control rule's bases. In addition, neural network control has been successfully used in many commercial and industrial applications in recent years. A Kohonen-type neural network was used for the position control of robot end-effector within 1 cm after learning [7]. Recently, the authors have developed a feed forward neural network controller and accurate trajectory following was obtained with an error of  $1[^\circ]$  [8]. An intelligent control using a neuro-fuzzy network was proposed by Iskarous and Kawamura [9]. A hybrid network that combines fuzzy and neural network was used to model and control complex dynamic systems, such as the PAM system. An adaptive controller based on the neural network was applied to the artificial hand, which was composed of the PAM [10]. Here, the neural network was used as a controller, which had the form of inverse of the model and it was not easy to apply these control algorithms to the PAM manipulator with high hysteresis, which is not modeled in the nonlinear inverse.

In addition, PID control is a very popular control strategy in industrial due to its simple architecture, easy tuning, cheap and excellent performance. However, the conventional PID is difficult to determine the appropriate PID gains in case of nonlinear and unknown controlled plants. Superb mixture of conventional PID controller and the neural network, which has powerful capability of learning, adaptation and tackling nonlinearity, brings us a novel nonlinear PID controller using neural network. The proposed controller is appropriate for a kind of plants with nonlinearity uncertainties and disturbances. In this paper, a nonlinear PID controller is newly proposed in order to improve

the control performance of the PAM manipulator. One link of the PAM manipulator is fabricated and the effectiveness of the proposed control algorithm is demonstrated through the experiments, which suggests its superior performance and disturbance rejection.

## 2. EXPERIMENTAL SETUP

### 2.1 Experimental apparatus

The schematic diagram of the PAM manipulator is shown in Fig. 1. The hardware includes an IBM-compatible personal computer (Pentium 1 GHz), which calculated the control input and controlled the proportional valve (FESTO, MPYE-5-1/8HF-710 B) through D/A board (Advantech, PCI 1720), and two pneumatic artificial muscles (FESTO, MAS-10-N-220-AA-MCFK). The rotating torque is generated by the pressure difference between the antagonist artificial muscles and the external load is rotated as a result. (Fig. 2) A joint angle  $\theta$  was detected by a rotary encoder (METRONIX, H40-8-3600ZO) and the air pressure into each chamber was also measured by the pressure sensors (FESTO, SDE-10-10) and fed back to the computer through a 24-bit digital counter board (Advantech, PCL 833) and A/D board (Advantech, PCI 1711), respectively. The experiments were conducted under the pressure of 0.4 [MPa] and all control software was coded in C program language. A photograph of the experimental apparatus is shown in Fig 3.

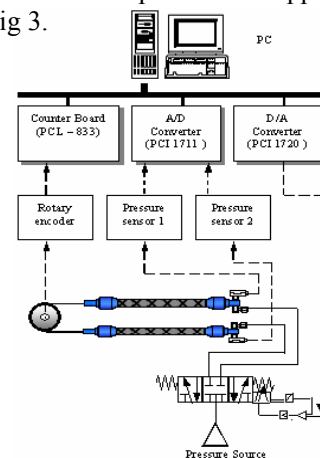

Fig. 1 Schematic diagram of PAM manipulator.

### 2.2 Characteristics of the PAM Manipulator

The PAM is a tube clothed with a sleeve made of twisted fiber-cords, and fixed at both ends by fixtures. The muscle is expanded to the radial direction and constricted to the vertical direction by raising the inner pressure of the muscle through a power-conversion mechanism of the fiber-cords. The PAM has the property of a spring, and can change its own compliance by inner pressure. A few sliding parts and a little friction are favorable for a delicate power control. But the PAM has the characteristics of hysteresis, non-linearity and low damping. Particularly, the system dynamics of the PAM changes drastically by the compressibility of air.

When using the PAM for the control of a manipulator, it is necessary to understand the characteristics of hysteresis, nonlinearity and so on. Therefore, the following experiments were performed to investigate the characteristics of the PAM. Figure 4 and 5 demonstrate the hysteresis characteristics for the joint. This hysteresis can be shown by rotating a joint along a pressure trajectory from  $P_1=P_{max}$ ,  $P_2=0$  to  $P_1=0$ ,  $P_2=P_{max}$  and back again by incrementing and decrementing the pressures of each chamber of the PAM using the proportional valve. The hysteresis of the PAM is shown in Fig. 6. The width of the gap between the two curves depended on how fast the pressures were changed; the slower the change in the pressures, the narrower the gap. The trajectory, control input to the proportional valve, velocity, and pressure of each chamber of the PAM are depicted in Fig. 5. The velocity is numerically computed from the position. Near the extreme values, the joint velocity decreased since the increase in exerted force for a constant change in pressure was less.

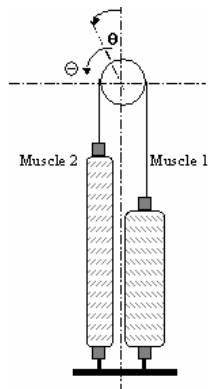

Fig. 2 Working principle of PAM

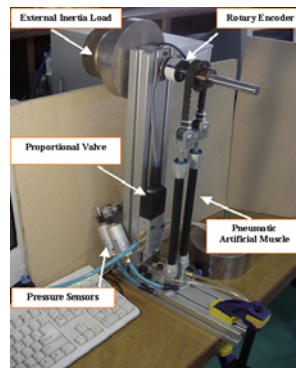

Fig. 3: Photograph of the experimental apparatus.

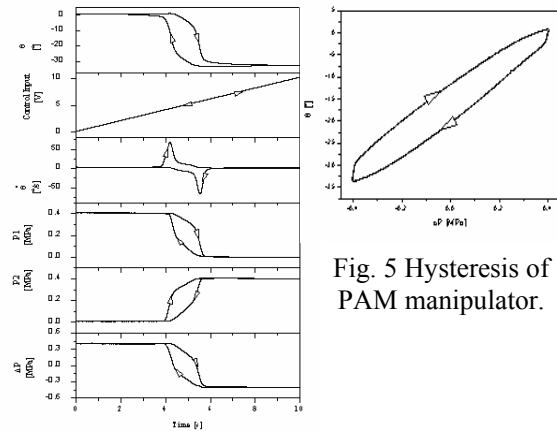

Fig. 4 Characteristics of PAM manipulator.

### 3. CONTROL SYSTEM

The strategy of PID control has been one of the sophisticated methods and most frequently used in the industry. This is because that the PID controller has a simple form and strong robustness in broad operating area. However, the requirement of control precision becomes higher and higher, as well as the plants become more and more complex. In order to achieve the satisfactory control performance, we have to consider the effect of the hysteresis and disturbance of the PAM manipulator. Hence, the conventional PID controller with fixed parameters may usually deteriorate the control performance. Various types of modified PID controllers have been developed such as intelligent PID control, self-tuning discrete PID controller, self-tuning predictive PID controller, and so on [11].

However, if severe nonlinearity is involved in the controlled process, a nonlinear control scheme will be more useful, particularly in case of high nonlinearity of the PAM manipulator. Nowadays, neural networks have been proved to be a promising approach to solve complex nonlinear control problems. Hence, it motivates us to combine neural network with PID control. It is anticipated that the combination will take the advantage of simplicity of PID control and the neural network's powerful capability of learning, adaptability and tackling nonlinearity.

The structure of the newly proposed nonlinear PID control algorithm using neural network is shown in Fig. 6.

Fig. 5 Hysteresis of PAM manipulator.

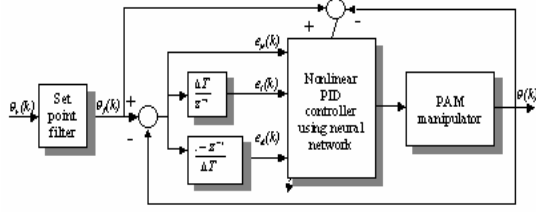

Fig. 6 Structure of the nonlinear PID controller using neural network.

This system with the set point filter and controller using neural network can solve the problems, which were mentioned in the introduction and are also useful for the PAM manipulator with nonlinearity properties. A control input  $u$  can be obtained from the following equation:

$$u = f(x) \quad (1)$$

Here  $f(\cdot)$  is the sigmoid function which has a nonlinear relationship as presented in the following equation:

$$f(x) = \frac{2(1 - e^{-x*Y_g})}{Y_g(1 + e^{-x*Y_g})} \quad (2)$$

where  $x$  is the input of sigmoid function and  $Y_g$  is the parameter determining its shape. Figure 7 shows the sigmoid function shapes with various  $Y_g$ . As shown in Eq. (2), the sigmoid function  $f(x)$  becomes linear function when  $Y_g$  becomes zero. The block diagram of neural network is shown in Fig. 8. Here,  $K_p$ ,  $K_i$ ,  $K_d$ ,  $e_p$ ,  $e_i$ , and  $e_d$  are the proportional, the integral, the derivative gain, the system error between desired set point filter output and output of joint of the PAM manipulator, the integral of the system error and the difference of the system error, respectively.

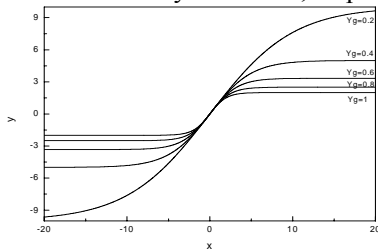

Fig. 7 The sigmoid function shapes

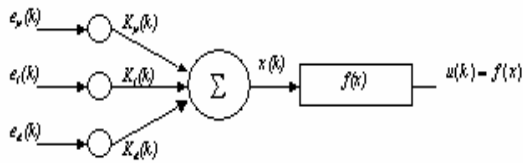

Fig. 8 Block diagram of neural network

We have a two-layered nonlinear neuron which has an input layer and an output layer. Neural networks are trained by the conventional back propagation algorithm to minimize the system error between the outputs of joint of the PAM manipulator and set point filter.

In Fig. 8, the input signal of the sigmoid function in the output layer,  $x$ , becomes:

$$x(k) = K_p(k)e_p(k) + K_i(k)e_i(k) + K_d(k)e_d(k) \quad (3)$$

where,

$$e_p(k) = \theta_f(k) - \theta(k); e_i(k) = \sum_{n=1}^k e_p(n)\Delta T$$

$$e_d(k) = \frac{e_p(k)(1 - z^{-1})}{\Delta T} \quad (4)$$

$\Delta T$  : sampling time,  $k$  : discrete sequence

$z$  : operator of Z - transform

$\theta_f(k)$  and  $\theta(k)$  are set point filter output and output of joint of the PAM manipulator, respectively.

To tune the gains of PID controller, the steepest descent method using the following equation was applied.

$$\begin{aligned} K_p(k+1) &= K_p(k) - \eta_p \frac{\partial E(k)}{\partial K_p} \\ K_i(k+1) &= K_i(k) - \eta_i \frac{\partial E(k)}{\partial K_i} \\ K_d(k+1) &= K_d(k) - \eta_d \frac{\partial E(k)}{\partial K_d} \end{aligned} \quad (5)$$

where  $\eta_p$ ,  $\eta_i$ ,  $\eta_d$  are learning rates determining convergence speed, and  $E(k)$  is the error defined by the following equation:

$$E(k) = \frac{1}{2} (\theta_f(k) - \theta(k))^2 \quad (6)$$

From Eq. (5), using the chain rule, we get the following equations:

$$\begin{aligned} \frac{\partial E(k)}{\partial K_p} &= \frac{\partial E(k)}{\partial \theta} \frac{\partial \theta(k)}{\partial u} \frac{\partial u(k)}{\partial x} \frac{\partial x(k)}{\partial K_p} \\ \frac{\partial E(k)}{\partial K_i} &= \frac{\partial E(k)}{\partial \theta} \frac{\partial \theta(k)}{\partial u} \frac{\partial u(k)}{\partial x} \frac{\partial x(k)}{\partial K_i} \\ \frac{\partial E(k)}{\partial K_d} &= \frac{\partial E(k)}{\partial \theta} \frac{\partial \theta(k)}{\partial u} \frac{\partial u(k)}{\partial x} \frac{\partial x(k)}{\partial K_d} \end{aligned} \quad (7)$$

The following equations are derived by using Eqs. (1), (3), (6):

$$\frac{\partial E(k)}{\partial \theta} = -(\theta_f(k) - \theta(k)) = -e_p(k)$$

$$\frac{\partial u(k)}{\partial x} = f'(x(k)); \quad \frac{\partial x(k)}{\partial K_p} = e_p(k); \quad (8)$$

$$\frac{\partial x(k)}{\partial K_i} = e_i(k); \quad \frac{\partial x(k)}{\partial K_d} = e_d(k)$$

And the following expression can be derived from these Eqs. (7), (8).

$$\frac{\partial E(k)}{\partial K_p} = -e_p(k) \frac{\partial \theta(k)}{\partial u} f'(x(k)) e_p(k)$$

$$\frac{\partial E(k)}{\partial K_i} = -e_p(k) \frac{\partial \theta(k)}{\partial u} f'(x(k)) e_i(k) \quad (9)$$

$$\frac{\partial E(k)}{\partial K_d} = -e_p(k) \frac{\partial \theta(k)}{\partial u} f'(x(k)) e_d(k)$$

$$\text{and } f'(x) = 4 \frac{e^{-x*Y_g}}{(1 + e^{-x*Y_g})^2} \quad (10)$$

As done by Yamada and Yabuta, for convenience,  $\frac{\partial \theta(k)}{\partial u} = 1$  is assumed [12]. Then the Eq. (5) is expressed as follows:

$$K_p(k+1) = K_p(k) + \eta_p e_p(k) e_p(k) \frac{4e^{-x*Y_g}}{(1 + e^{-x*Y_g})^2}$$

$$K_i(k+1) = K_i(k) + \eta_i e_p(k) e_i(k) \frac{4e^{-x*Y_g}}{(1 + e^{-x*Y_g})^2} \quad (11)$$

$$K_d(k+1) = K_d(k) + \eta_d e_p(k) e_d(k) \frac{4e^{-x*Y_g}}{(1 + e^{-x*Y_g})^2}$$

The effectiveness of the proposed nonlinear PID control strategy with tuning algorithm of  $K_p$ ,  $K_i$ ,  $K_d$  will be demonstrated through experiments of position control with various loads.

#### 4. EXPERIMENTAL RESULTS

Experimental results were carried out in two cases: without external inertia load and with external inertia load (20kg.cm<sup>2</sup>), and the comparison between the conventional PID controller and the proposed nonlinear PID controller was presented.

The set point filter was designed as follow:

$$F(s) = \frac{2500}{s^2 + 100s + 2500} \quad (12)$$

Fig. 9 shows the experimental results of conventional PID controller in condition 1, where the parameters of PID controller are set to

be  $K_p = 500 \times 10^{-6}$ ,  $K_i = 10 \times 10^{-6}$  and  $K_d = 78 \times 10^{-6}$ . The optimal parameters of PID controller were obtained by trial-and-error through experiments. From Fig. 9, there was no overshoot in the response of the PAM manipulator. However, it had a long settling time and there was a large tracking error with respect to the output of set point filter. Next, the experiments were carried out to verify the effectiveness of the proposed nonlinear PID controller using neural network. Fig. 10 shows the comparison between the conventional PID controller and the proposed nonlinear PID controller without external inertia load, and the updating of each control parameter ( $K_p$ ,  $K_i$  and  $K_d$ ) was shown in Fig. 11. In the experiment of the nonlinear PID controller, the initial values of  $K_p$ ,  $K_i$  and  $K_d$  are set to be  $100 \times 10^{-6}$ ,  $10 \times 10^{-6}$  and  $10 \times 10^{-6}$ , respectively, and the learning rates in Eq. (9) are set to be  $\eta_p = 6.5 \times 10^{-6}$ ,  $\eta_i = 0.01 \times 10^{-6}$  and  $\eta_d = 0.06 \times 10^{-6}$ , respectively. The optimal parameters of learning rates were also obtained by trial-and-error through experiments. From Fig. 10, it was understood that the system response of the proposed controller was in good agreement with that of set point filter and it was demonstrated that the proposed algorithm was effective in the no external load condition. From Fig. 11, the change of each control parameter was shown, where the damping parameter ( $K_d$ ) increased rapidly in the transient time and decreased quickly after the end of rising time.

Next, experiments were carried out to investigate the control performance with external inertia load. In Fig. 12, the experiment results with and without external load by using conventional PID controller were explained. In the experiments, the same control parameter in the condition without external inertia load was used and the control performance became deteriorated and some oscillation happened in the case of applying external load. Therefore, it was requested that the control parameters should be adjusted according to the change of the external inertia load.

In Fig. 13, comparison between the conventional and the proposed PID controller was performed. The initial values of  $K_p$ ,  $K_i$  and  $K_d$ , used in this experiment, were the same as

those of no external inertia load. The gain tuning of PID controller was shown in Fig 14. The effectiveness of the proposed nonlinear PID controller with respect to the change of external inertia load was verified by the above experiments.

The proposed nonlinear PID controller using neural network with compensation for nonlinear plants has shown that not only it was very effective in the accurate position control of the PAM manipulator, but also it made the system more robust with respect to the change of plant parameter.

## 5. CONCLUSIONS

A new kind of nonlinear PID control using neural network was proposed in this study. It has shown that the proposed method had a good control performance for the nonlinear system, such as the PAM manipulator. The controller had an adaptive control capability and the control parameters were optimized via the back propagation algorithm. The controller designed by this method does not need any training procedure in advance, but it uses only the input and output of the plant for the adaptation of control parameter and can tune the parameters iteratively.

From the experiments of the position control of the PAM manipulator, it was verified that the proposed control algorithm presented in this study was online control with simple structure and had better dynamic property, strong robustness and it was suitable for the control of various plants, including linear and nonlinear process, compared to the conventional PID controller.

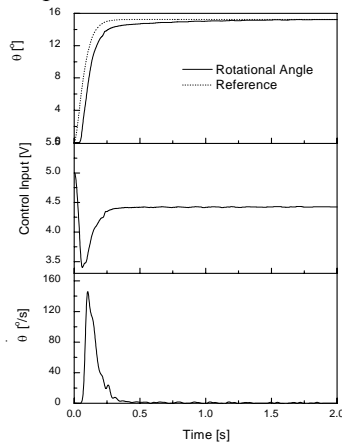

Fig. 9. Experimental results of conventional PID controller without external inertia load.

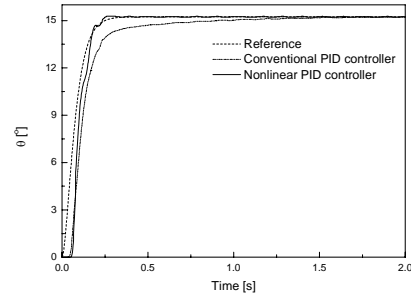

Fig. 10 Comparison between conventional PID controller and nonlinear PID controller using neural network without external inertia load.

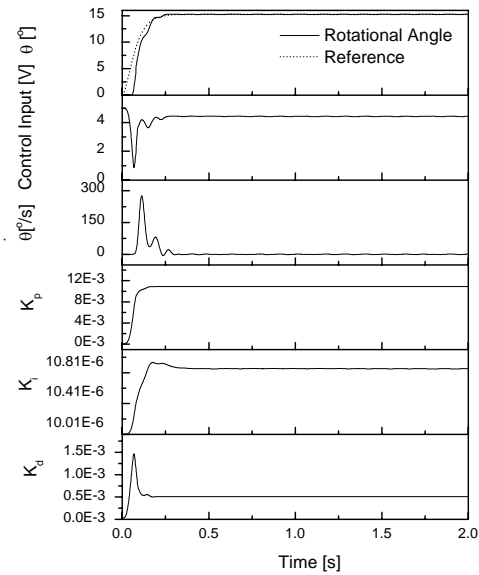

Fig. 11 Experimental results of nonlinear PID controller using neural network without external load.

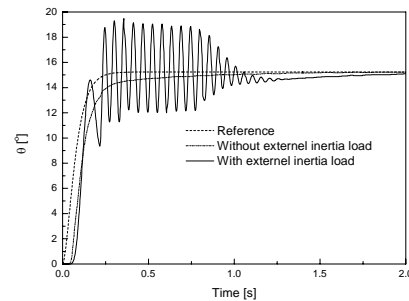

Fig. 12 Experimental results of conventional PID controller with and without external inertia load.

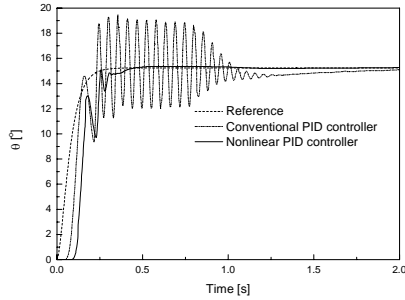

Fig. 13 Comparison between conventional PID controller and nonlinear PID controller using neural network with external inertia load.

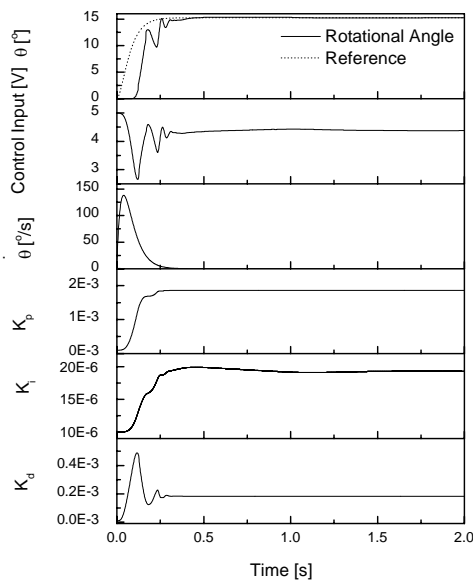

Fig. 14 Experimental results of nonlinear PID controller using neural network with external load.

## REFERENCES

1. Repperger, D., W., Johnson, K., R., Phillips, C.,A., "Nonlinear feedback controller design of a pneumatic muscle actuator system," in Proc., American Control Conference, Vol. 3 (1999), pp. 1525-1529.
2. Caldwell, D. G., Medrano-Cerda, G. A., and Goodwin, M. J., "Braided pneumatic actuator control of a multi-jointed manipulator," in Proc., IEEE Int., Conf., Systems, Man and Cybernetics, (1993) pp. 423-428.
3. Cai, D., Yamaura, H., "A VSS control method for a manipulator driven by an

McKibben artificial muscle actuator," Electron, Commun, (1997), No. 3, pp. 55-63.

4. Tondu, B., and Lopex, P., "Modeling and control of McKibben artificial muscle robot actuators." IEEE Contr., Syst., Mag., Vol. 20 (2000), No. 1, pp. 15-38.

5. Osuka, K., Kimura, T., Ono, T., "H $\infty$  control of a certain nonlinear actuator," in Proc., IEEE Int., Conf., Decision and Control, Vol. 1 (1999), pp. 370-371.

6. Balasubramanian, V., Rattan, K.S., "Feedforward control of a non-linear pneumatic muscle system using fuzzy logic," in IEEE Int., Conf., Fuzzy Systems, Vol. 1 (2003), pp. 272-277.

7. Hesselroth, T., Sarkar, K., Patrick van der Smagt, P., and Schulten, K., "Neural network control of a pneumatic robot arm," IEEE Trans Syst., Man., Cybernetics, Vol. 24 (1994), No 1, pp. 28-38.

8. Patrick van der Smagt, P., Groen, F., and Schulten, K., "Analysis and control of a Rubbertuator arm," Biol. Cybernet., Vol. 75 (1996), pp. 433-440.

9. Iskarous, M., Kawamura, K., "Intelligent control using a neuro-fuzzy network," in Proc., IEEE/RSI Int., Conf., Intelligent Robots and Systems, Vol. 3 (1995), pp. 350-355.

10. Folgheraiter, M., Gini, G., Perkowski, M., and Pivtoraiko, M., "Adaptive Reflex Control for an Artificial Hand," in Proc., SYROCO, Symposium on Robot Control, Holliday Inn, Wroclaw, Poland (2003).

11. Astrom, K., J., Hang, C., C., Persson, P., and Ho, W., K., "Toward intelligent PID control," in Int., Conf., Automatic, Vol. 28 (1992), pp. 1-9.

12. Yamada, T., Yabuta, T., "Neural network controller using autotuning method for nonlinear functions," in IEEE Trans., Neural Networks, Vol. 3 (1992), pp. 595-601.